

MEETINGS, NETS and SERVICES**Club Station:** VK4WIS**Club Repeaters:**

Wilkes Knob: VK4RSC on 146.850 MHz & 438.075 MHz.

Luguna Lookout: VK4RMB on 146.825 MHz & 438.175 MHz

Wilkes Knob: VK4RSN on 53.700 MHz

Gympie (private): 146.725 MHz

General Meeting: Monthly on the first Tuesday at 7:30 pm in the Club House, old Toll Plaza building, 85 Godfreys Road, Bli Bli.

Visitors are welcome to attend.

Weekday Meeting: Weekly at 10:00 am—2:00 pm on Wednesday.

Sunday Meeting: 3rd Sunday of each month at 10:00—2:00 pm.

Good Morning Net: Daily at 8.15 am at VK4RSC on 146.850 MHz. Conducted by various club members.**Tech Net:** Weekly at 8:30 pm Sunday at VK4RSC on 146.850 MHz. Check in, raise topics and ask your technical questions.**80 m Net:** Weekly at 7:30 pm Thursday on 3660 kHz.**10 m Net:** Weekly at 8:15 pm Wednesday on 28.470 MHz USB.**6 m Net:** Weekly at 7:30 pm Friday at VK4RSN on 53.700 MHz.**2 m Net:** Weekly at 7:30 pm Sunday on 144.300 MHz USB.**2 m Net:** Weekly at 7:30 pm Monday on 147.975 MHz.

Conducted by club station VK4WIS.

QNEWS: Relayed Sunday at 9:00 am at VK4RSC on 146.850 MHz. After the broadcast a callback is conducted by VK4WIS.**Internet:** www.vk4wis.org

This website provides previous issues of Pelican Droppings in full colour in pdf format which can be downloaded.

The current issue can be had by subscribing to the email edition in pdf format. Apply to SCARC.

EchoLink: Available on VK4RSC 146.850 MHz.

The Internet station is VK4WIS-R and the node is #316084.

Pelican Droppings

Newsletter of the Sunshine Coast Amateur Radio Club Inc.

Issue No.95

June—July 2008



**Col McCamley Award for 2008 goes to Richard Philp VK4YRP
Presented by SCARC president Noel Des Jardins VK4NL**

NEXT ISSUE

A Tony Thorrold article of fuses.

SCARC Inc. Office Bearers AGM March 2008

President	Noel Des Jardins VK4NL
Vice-President	Frank Winter VK4BLF
Secretary	Gordon Taylor VK4VP
Treasurer	Keith Noll VK4AKA
Committee	Ray Stuart VK4YRS; Mike Little VK4YFL; Richard Philp VK4YRP

Copy deadline: 3rd Tuesday of the month preceding GM issue.

Email editor: gcombes4@bigpond.com**INSIDE**

SCARC Calendar of Events—update	Page 4
Video & AF connector pinouts for TV, DVD & PC	Page 5
WICEN radios in programming phase	Page 6
Glorifying the Crystal Set	Page 8
The Class D RF Amplifier—Part 2	Page 10
70 cm Yagi antenna	Page 12

Address: The Secretary, Sunshine Coast Amateur Radio Club Inc.
PO Box 7551, Sippy Downs, Qld. 4556



Presidential Preamble

Hi all, time to let you all in on what's been happening.

Our repeater committee have been at a stand still, owing to the inclement weather and were not able access towers to fit antennas and feed lines until the weather cleared. Then Warwick VK4NW headed overseas with wife Trish for two months leaving the repeater team down one, and Richard VK4YRP and wife Win also headed for Victoria for a break. This left Keith VK4AKA holding the fort. Also noted is that Dave VK4UN and his wife Sylvia are heading for Broome for a long-earned holiday. Safe trip.

By the time the team returned the weather had cleared and action on Wilkes Knob began again in earnest. Keith VK4AKA and team comprising Richard VK4YRP, Tony VK4GEP, Vin VK4FVCW (welcome back) who worked aloft and Warwick VK4NW, David VK4JMR, David VK4HFW, Harvey VK4AHW, Bill VK4XZ and Wayne VK4WS who put on line the two meter repeater VK4RSC at 146.850 MHz. Further like work is to happen on all our repeaters sites in the near future. We will keep you informed through our monthly General Meetings and on this column. The repeater was initially plagued by interference and we have Wayne VK4WS and Keith VK4AKA to thank for the long hours spent solving that problem.

The weekend Rally Q in the hills of Imbil was the next event. It was an eye opener for me as a first timer. Teams from the club operated all checkpoints and provided communications on packet and voice radio throughout the event. The Brisbane Digital Group provided the organisation as they have done for past years. Another job well done by them..

Our clubrooms activities are going ahead full steam. Top marks to all who help out around the clubrooms. Robert VK4FVMP is keeping the yard looking tidy and Harvey VK4AHW is doing the same in the workshop. Leicester VK4ALH is now working in the store. Thanks to all.

Next up was our EMQ WICEN photo shoot - what an unruly lot. Eventually some realised that they had to smile. All enjoyed the morning tea and sausage sizzle; Geoff VK4KE taking over the BBQ.

70 cm Yagi (continued)

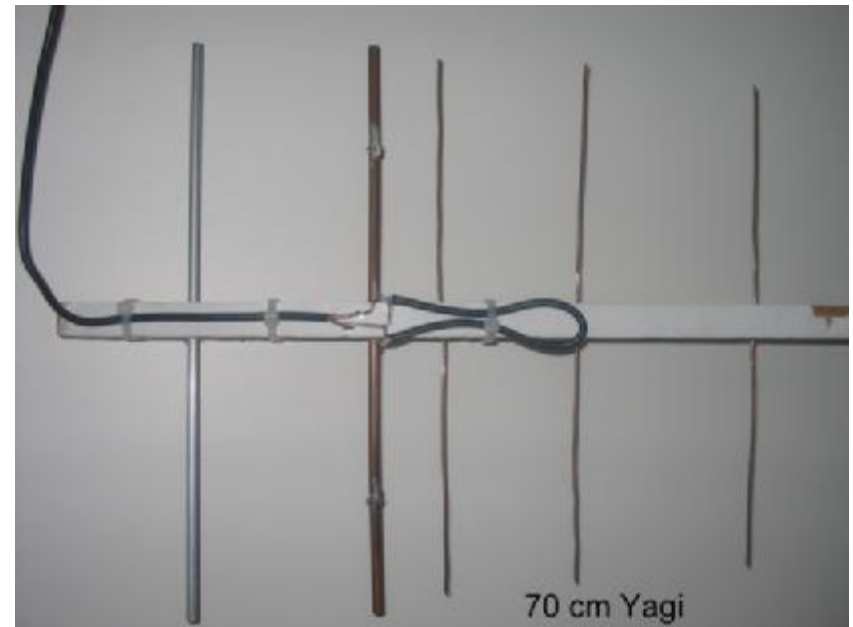

ADVERTISEMENT

NISSEN TECHNOLOGIES

tel 07 5455 6476

www.nissentechnologies.com

shop 11 Noosa outlook s.c.
st. andrews drive
tewantin

Advertisement

**NORTHCOAST
Glass & Aluminium**

24 hour glass repair
7 days a week

Lawrence Swift
Pamela Swift
Proprietors

17 Mitchell St, NAMBOUR, QLD, 4560

Ph: (07) 5476 2799 Fax: (07) 5476 2987

70 cm Yagi (continued)

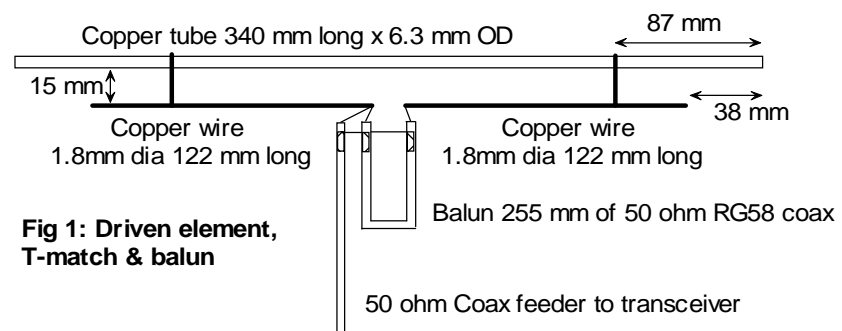

Fig 1: Driven element, T-match & balun

A new Gympie Group has been formed with the objective of re-creating a Gympie radio club. On behalf of the SCARC Club I wish them all the best in their endeavour. We offer them assistance.

I should mention club members on the sick list: Angus VK4QV, Ruth VK4HEY, Bill VK4SQ, Al VK4LT, Les VK4YI, Rod VK4MRC and Tony VK4TLA. We wish them a speedy recovery.

Now I'll leave you to read the rest of Pelican Droppings.

Noel VK4NL

Advertisement

LEADING EDGE ELECTRONICS
Business Pty Ltd (The Leading Edge Electronics & Computers Collection)

Emma Bowley
 Managing Director
 Mobile: 0408 118 309

Derek Hicks
 Managing Director
 Mobile: 0405 972 161

Shop 1, 14 Bowman Road
 The Bowman Centre
 Caloundra Qld 4551

Ph: (07) 5491 9332
 Fax: (07) 5491 9311

Email: leecabound@ircn.com.au
 www.leadingedgeelectronics.com.au

Jaycar
Electronics & Computers

ADVERTISEMENT

Fax 54917865 Ph 54926260

Alcorn's Communications & TV Antenna Service

INTERCOMS ALARMS

TWO-WAY RADIO — ANTENNA INSTALLATION

12 IVY STREET CALOUNDRA QLD 4551
 Email: alcornscomm@smarchat.net.au

Clayton's
TOWING SERVICE
PTY LTD ABN 66 0191 423 117

Mike Clayton
 0418 711 008
Tel: 07 5441 3888



The repeater team at work aloft the Wilkes Knob tower installing antenna and feed lines for the 2 m repeater VK4RSC

SCARC Calendar of Events 2008

June 20,21,22 Rally Qld (Gary Bonnor VK4ZGB)
 July 1 General meeting 7.30 pm
 July 4 Winter HASH NIGHT 6-9 pm Friday night) at Dave Robertson VK4JMR 32 Quambi Place, BUDERIM
 July 13 Noosa Endura Bike Ride
 August 5 BBQ at 6 pm followed by general meeting at 7.30 pm
 August 16 HAM COOKOUT and LIGHTHOUSE weekend 4.30-8 pm Saturday evening at the old Caloundra lighthouse. Radios will be working HF/VHF on different bands to other light-houses, our pavilion will be up, and our BBQ will be fired up for a cookout. BYO XYL, food, kids/grandkids. http://illw.net/contact_us.php
 Sept 2 General meeting 7.30 pm
 Sept 13 SUNFEST at Woombye Hall (contact Harry VK4TK)
 Oct 3 Spring HASH NIGHT 6-9 pm (Friday night) at Harvey Wickes VK4AHW's QTH Buderim
 Oct 7 General meeting 7.30 pm
 Oct 11,12 at Lake Dyer (Bill Gunn Dam) Laidley we will hold our first October Inter-club SCARC DALBY CAMP and HAM COOKOUT <http://sweetwaterfishing.com.au/Dyer.htm> Contact Noel VK4NL for van site bookings.
 Oct 18,19 Jamboree of the air and also President's Lunch.
 Nov 4 General meeting 7.30 pm
 Dec 2 Early 6 pm Meeting and Family Christmas BBQ
 Jan 9 Summer HASH NIGHT 6-9 pm (Friday night) at Geoff Sanders VK4KEL's QTH Chevallum

HAMS AT SOMEONE'S HOUSE

Seasonal HASH night (unplug your radios and enjoy a someone else's cooking) BBQ, seats, music, etc. provided.
 Bring a bowl of main course or dessert to share with others. Friday nights for your XYL, family and friends to unwind from the week with good cooking and good company.
 Drinks are fine to bring along—BYO or to share.

Element No.	Distance from Refl.	Element length
Reflector	0	346
Driven Element	104	340
Director 1	147	321
Director 2	226	311
Director 3	334	294
Director 4	468	294
Director 5	609	293
Director 6	754	291
Director 7	970	290
Director 8	1190	288
Director 9	1408	287



present form it would be quite adequate for indoor / attic use, but for outdoors it would need to be waterproofed and the copper wire is too soft - the elements would need to be mechanically stronger.

The design is loosely based on one given in the ARRL Antenna Book, 19th edition.

[Diagram and another photo on next pages]

End

70 cm Yagi Antenna

by Tony Thorrold VK4KKY

Having recently joined the ranks of 70 cm amateurs and living out of “rubber ducky range” of any repeaters, I decided to build an antenna with some gain. I chose the first design just because it looked interesting: a Quagi. This is like a Yagi, but the reflector and the driven element are quads while the directors are normal Yagi-type straight elements. After weeks of fiddling and experimenting, I found out why there is not a Quagi on every Amateur’s roof or tower – it doesn’t work!

Reverting to the well-tryed Yagi principle resulted in an antenna I am delighted with. It loads up perfectly, has a SWR of 1:1 and gets out well. It is still in the prototype stage, but this is what it consists of: The boom is a 1.6 metre length of 20 mm x 40 mm wood.

The 9 directors are 1.8 mm dia. copper wire; off-cuts of 2.5 sq mm house wiring.

The reflector is ¼ inch (6.3 mm) aluminium tube (because I had it) The driven element is ¼ inch (6.3 mm) copper tube (so I could solder it) and is fed with a T-match and a ½ λ coaxial balun. The T-match transforms the balanced feed point impedance of the Yagi up to 200 ohms, while the coaxial balun with its 4:1 ratio matches the balanced Yagi’s impedance to 50 ohm unbalanced coax. A detailed drawing of the driven element is shown in Fig 1 (page 14) and the photos further illustrate the antenna. The table gives the lengths of the elements and the spacing between them.

I’m sure that with an antenna analyser, a field strength meter and a computer-optimising program it would be possible to improve the performance, but as it is, it works very well for what I need. In its

Advertisement

NKR Computer Services
A.B.N.: 43 513 0687
NICK KAIL - WISE (Microsoft) - CCDA (CISCO)

- Virus Removal
- Network Design
- Configuration & Installation
- PC & Server Upgrades
- PC & Server Repairs
- System Maintenance
- Competitive Rates
- Work Guaranteed

Phones: (07) 54 913637
Mobile: 0439 603200
Fax: (07) 54 911637
E-mail: nkrcs@yashoe.com.au

Address:
9 Basree Street
Caloundra, 4551
Q.L.D.

Video and Audio connector pinouts for TV, DVD, PC

by Geoff Combes VK4GWC

My TV is an Orion of European design. It has video and audio sockets at the front and at the back. At the back there is also a VGA socket. The socket at the front are weakly attached to the PCB. It is better to use the sockets at the back. However the video/audio connectors are 21-pin SCART Euro AV. There are two: one called AV1 is the original Euro standard that provides for composite video input/output, RGB inputs and stereo audio; the other called AV2 provides for S-video and stereo audio.

Presently I use an S-video/S-video cable to connect both the digital TV set-top box and DVD player to the TV via the S-video socket at the front. I am obliged to switch manually by unplugging/plugging from STB and DVD player. My plan was to use the video inputs at the back of the TV, thereby avoiding the manual changeover. AV1 SCART would be used for the DVD player (RGB, not composite) and AV2 SCART would be used for the STB (S-video/stereo audio).

To make sure I bought the right cables I wanted to check the pinouts of the SCART connectors. I found these relatively easily on the Internet at this URL: <http://acl.co.uk/pinouts.html>. The seven page printout provides pinouts for both SCART 21-pin Euro Av connectors, S-video 4-pin connector, 9- and 15- pin VGA connectors for both IBM and MAC II video and a 100 Base T Crossover cable used to connect two network interface cards. Most cables are available from stores like Jaycar. End

Advertisement

VK4-ICE Communications
Amateur Radio Products, Antennas, Mobile Mounts
Delivered anywhere in Australia.

WWW.VK4ICE.COM
David Tavener
ABN: 44 680 867 684
vk4ice@vk4ice.com
Phone: 0408 763 336

WICEN radios in programming phase

Editorial with Bill Sebbens VK4XZ

There are ten new WICEN FM transceivers now being programmed by Bill Sebbens VK4XZ at home. I found Bill on a recent Wednesday midday meeting with two of them. Both are commercial radios covering different VHF bands.

The one shown in Fig.1 is a TAIT 2020 with power output of 25 W and a frequency range of 70 - 85 MHz. It is programmed with channels for Rural Fire Brigade, Forestry and National Parks and the Maroochy and Noosa branches of the Sunshine Coast Regional Council.

The other shown in Fig.2 is a VERTEX (aka Yaesu) 2200 series with power output of 25 W and a frequency range of 136 - 170 MHz. It has channels for the amateur 2 metre band of 144 - 148 MHz. Caloundra branch of the Regional Council on 174 MHz and Marine radio frequencies from 150 - 160 MHz.

The other eight radios include models for UHF for the 70 cm amateur radio, SES and urban fire brigades. More on WICEN radio communications as progress is made fitting them out in the caravan. End

Fig.1 TAIT radio for channels in the band 70—85 MHz

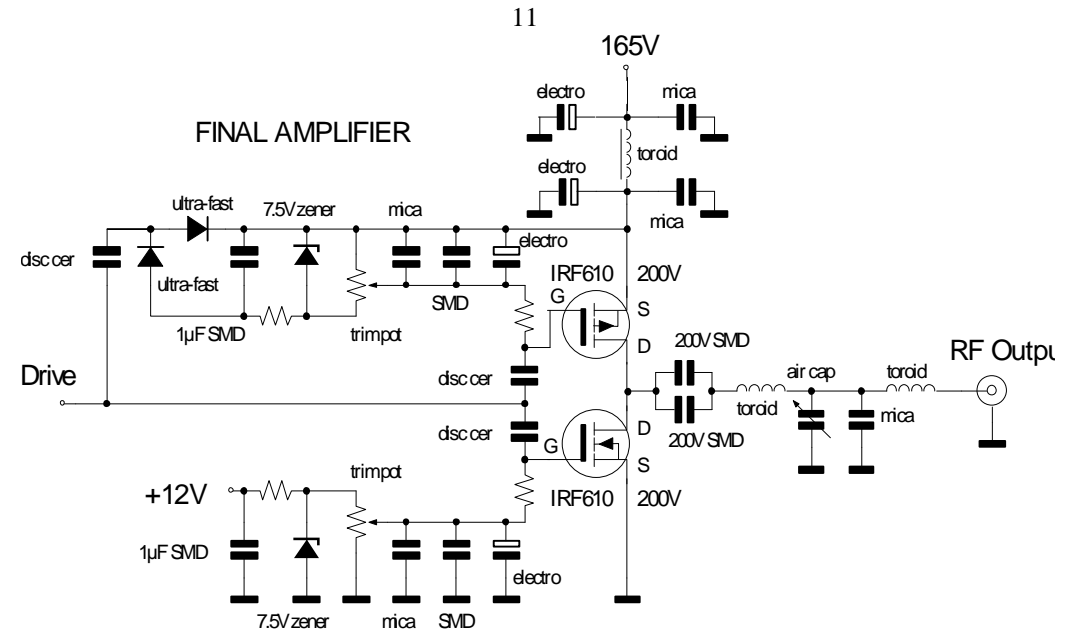

Fig.2 100 W Class D transmitting amplifier

Figure 2 shows the circuit diagram of the final amplifier. It consists of a complementary pair of 200-V power mosfets (type IRF610) driven in a manner so that any RF drive pushes one into an on state and the other into an off state. Gate biases come from two 7.5 V zener diodes. Bias for the n-channel mosfet derives from a +12 V supply. The source of the P-channel mosfet is connected to the main DC supply which may be variable. Therefore the bias for the source must float against the main supply. This is achieved by deriving a voltage of about -12 V from the RF input drive via a DC isolating capacitor and ultra-fast diode rectifiers for use as bias.

The output network provides a 50 ohm load to the mosfet drains and high impedance harmonics through a T-filter. The authors claim a straight-line transfer curve and IMDs less than -50 dBc. With a mains supply of 165 V power output was measured at 100 W at 500 kHz and down to 92 W at 3.5 MHz. Corresponding efficiencies were 90% down to 83%.

Ref: A 100-W Class-D Power Amplifier for LF and MF, F.H.Raab W1FR, M.Gladu N1FBZ and D. Rupp, QEX Mar-Apr 2006 Issue No.235 (Note: the P-channel mosfet is shown upside down in Fig.3. The source is connected to the power supply as stated in the text. End

The Class D RF Amplifier - Part 2 An Amplifier

by Geoff Combes VK4GWC

In the Feb-Mar 2008 issue I introduced the Class D RF amplifier. In this final part we look at a powerful but simple example of an amplifier of this type, one built and tested for 80 or 160 m bands by some amateurs in USA (see reference below). The design consists of two parts: the first is a driver that accepts low power RF (say, from an HF transceiver) and has a keyed square wave RF output; the second is the 100-W power amplifier. The two parts are assembled on a single printed circuit board measuring about 250 x 80 mm.

Figure 1 shows the circuit diagram of the driver. The RF signal input is either 3 V (peak) sine wave, TTL or 1 V peak square wave. The gate driver converts the input signal into square-wave drive for the power amplifier. Keying for CW operation is accomplished by turning the drive on and off using a simple key and a transistor. The input resistors and capacitor to the transistor base serve to shape the waveform to avoid key clicks. A rise/fall time of about 10 ms is achieved.

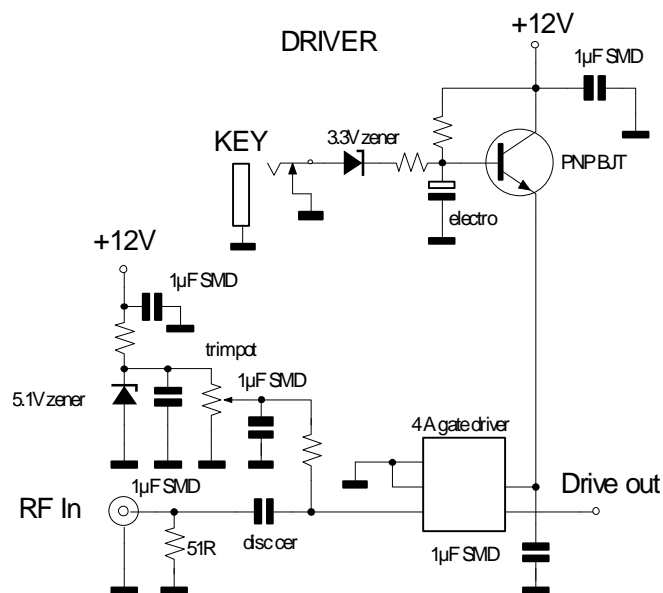

Fig.1 Driver for Class D amplifier



Fig.2 VERTEX radio for channels in the band 136—170 MHz

ADVERTISEMENT

**Suncoast
CARAVAN
Service**

Bruce & Jenny BEAUSANG

Caravan Repairs ★ Spare Parts & Accessories
Roadworthy & Gas Certificates ★ Insurance Quotes
17 Fishermans Rd, Maroochydore 4558
Ph: (07) 5443 1036 - Fax: (07) 5443 1160
Email: suncoastcaravans@bigpond.com

Advertisement

D&A Crane Hire Noosa

0419 735 748

ASHLEY
0428 741 464
a/h 5474 1464

DAVID
0419 735 748
a/h 5474 3305

FAX 07 5474 3809
PO BOX 885, TEWANTIN 4565

The Glorious Crystal Set

Demonstrated by Dennis Griggs VK4FDMG

The simplicity of the humble crystal set does not prevent it from being made most glorious, and this has been demonstrated magnificently by Dennis Griggs VK4FDMG. The photographs below show the two versions that he built. Both use actual crystals (not Ge diodes) housed in transparent enclosures with adjustable point contact cats whiskers for finding the right spot for RF (diode) detection. Note too the large coils for high Q and best selectivity. End

