

**MEETINGS, NETS and SERVICES****Club Station:** VK4WIS**Club Repeaters:**

Maleny: VK4RSC on 146.850 MHz &amp; 438.075 MHz.

Peregian Beach: VK4RMB on 146.825 MHz &amp; 438.175 MHz.

Gympie: VK4RGY on 146.625 MHz &amp; 438.825 MHz.

Bli Bli: VK4RSN on 53.700 MHz

**General Meeting:** Monthly on the first Tuesday at 7:30 pm in the Club House, old Toll Plaza building, 85 Godfreys Road, Bli Bli.

Visitors are welcome to attend.

**Weekday Meeting:** Weekly at 10:00 am on Wednesday.**Good Morning Net:** Daily at 8.15 am at VK4RSC on 146.850 MHz.  
Conducted by various club members.**Tech Net:** Weekly at 8:30 pm Sunday at VK4RSC on 146.850 MHz.  
Check in, raise topics and ask your technical questions.**80 m Net:** Weekly at 7:30 pm Thursday on 3660 kHz.**10 m Net:** Weekly at 8:15 pm Wednesday on 28.470 MHz.**6 m Net:** Weekly at 7.30 pm Friday at VK4RSN on 53.700 MHz.**2 m Net:** Weekly at 7:30 pm Sunday on 144.300 MHz SSB.  
Conducted by club station VK4WIS.**QNEWS:** Relayed Sunday at 9:00 am at VK4RSC on 146.850 MHz.  
After the broadcast a callback is conducted by VK4WIS.**Internet:** [www.vk4wis.org](http://www.vk4wis.org)

This website provides previous issues of Pelican Droppings in full colour in pdf format which can be downloaded.

The current issue can be had by subscribing to the email edition in pdf format. Apply to SCARC.

**EchoLink:** Available on VK4RSC 146.850 MHz.

The Internet station is VK4AKA-R and the node is #195107.

The intention is to have the next issue out by the June GM or soon after, and the following issue out at the scheduled time of the August GM. This will recover the month lost with this issue.

**NEXT ISSUE****SCARC Inc. Office Bearers AGM Feb 2006**

President	Ray Stuart VK4YRS
Vice-President	Noel Des Jardins VK4NL
Secretary	Gordon Taylor VK4VP
Treasurer	Keith Noll VK4AKA
Committee	Harvey Wickes VK4AHW; Frank Winter VK4BLF; Mike Little VK4YFL; Richard Philp VK4YRP

Copy deadline: 2nd Tuesday of the month preceding GM issue.

Email editor: [geoffcom@powerup.com.au](mailto:geoffcom@powerup.com.au)

# Pelican Droppings

Newsletter of the Sunshine Coast Amateur Radio Club Inc.

Issue No.83

April-May 2006

'Look into my eyes, ye mighty, and despair', see page 2

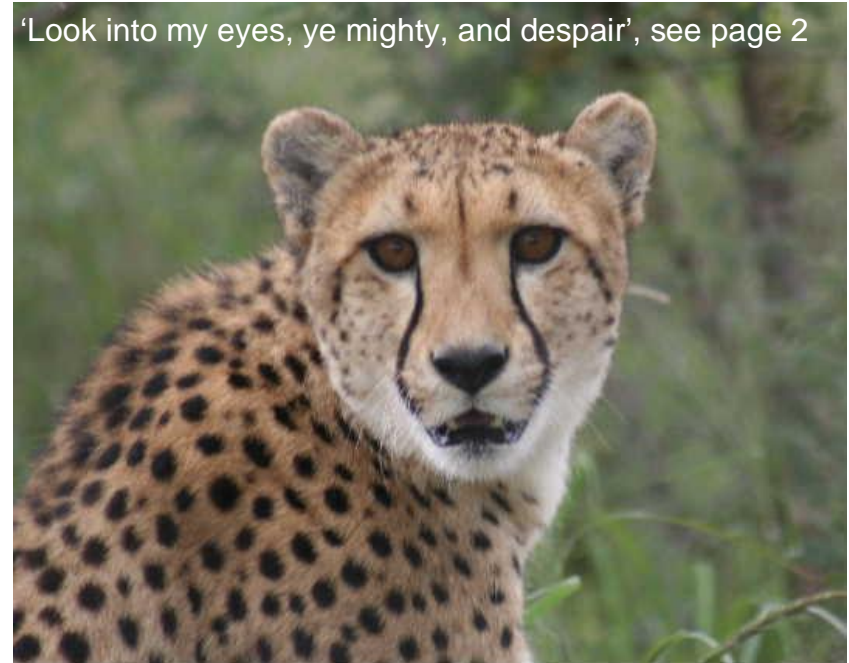
**INSIDE**

Somerset Dam Meet	Page 3
Using a PC Serial I/O Controller & Analog Sampler	Page 5
China Odyssey—Part 4, Shanghai	Page 9
Barcfest advertisement	Page 11
Integrated Circuits—PD Tech Review	Page 12
Car Radio Installation	Page 13
Hedy Lammaar—Communications innovator	Page 14

Address: The Secretary, Sunshine Coast Amateur Radio Club Inc.  
85 Godfreys Road Bli Bli Qld 4560



## Presidential Preamble

### Repeaters

Our repeater officer Keith VK4AKA has had a 70cm repeater ( 438.175 MHz ) on test at Dulong. Next his repeater will be tested at Gympie township. Should members be satisfied with its coverage then that will be its permanent home. Currently a two metre repeater ( 146.825 MHz) is being tested at the Dulong site. Give it a try and let Keith know your results.

### Clubroom happenings

Education is conducted for the new Foundation Licence plus Standard and Advanced Licences by Harvey VK4AHW. Speak to him if you are interested.

Bill and his crew are still working in the Green Room. New coax has been run to the mast and terminated with antennas for VHF and UHF emergency frequencies. The committee has given \$200 to assist finishing this work.

Max VK4VZ retired from being our librarian. Thanks to Max for the hours of work he has put in chained to his chair in the depths of the building. He has catalogued hundreds of books and given us one of the best amateur radio club libraries in Queensland. Vicki, wife of Harry VK4TK, who has been helping Max, has agreed to be our new librarian. She could use help, so please offer your assistance.

With Joe VK4SY being away for a skin graft, people have been running amok in the South Yarra store. Joe will need a hand when he returns to store work.

Our May 2006 night meeting is on Tuesday 2nd at 7:30pm at the clubrooms. The next Sunday meeting will be held on the 21st of May 2006 starting at 9:00 AM at the clubrooms. BYO BBQ.

The club net controllers give their time freely, so please join them.

The SCARC web site URL is [www.vk4wis.org](http://www.vk4wis.org). Check it for updates.

To those on our sick list we all hope that they improve daily.

That's enough from me.

73 all, Ray

### Front page photograph

Taken by Ron Marschke VK4GZ while on a recent tour of the Republic of South Africa. Camera was a Canon EOS 350D DIGITAL. An excellent close-up of a beautiful animal.



**Hedy Lamarr—movie star, radio communications innovator**

cal engineering professor from the California Institute of Technology, they miniaturised and debugged the system and patented their “Secret Communication System” on 11 August 1942, at the height of her Hollywood film career.

The US Navy refused to consider the system, scathingly remarking that there was no space for a piano in a torpedo. They were unwilling to consider the idea that music technology could play a role in a weapon of war. Immediately the patent expired, engineers at the Sylvania Electronic Systems Division took up the idea, but implemented it in an electronic rather than a mechanical manner. It became widely adopted by the military and is used today by the US government’s Milstar defence communication satellite system and is also the basis of all modern cellular phone technology. Lamarr and Antheil never received credit or royalty payments for their idea – it was an invention 20 years ahead of its time. However, before her death in January 2000, Hedy was honoured with an industry award for ‘blazing new trails on the electronic frontier’. End

### Famous Personalities: Hedwig Eva Maria Kiesler

By Tony Thorrold VK4KKL

Kiesler (1914 – 2000) was born in Vienna, Austria. In the early 1930s she went to acting school in Berlin and in 1933 she starred completely nude in the film *Ecstasy*, a shocking scandal in those days. That year she married Fritz Mandl, an armaments manufacturer, and in their home in Vienna they lavishly entertained many important industrialists and world leaders, including Hitler and Mussolini. Mandl was very interested in radio control systems for his weapons and Hedy would listen in on the conversations around the dinner table. She once said, 'Any girl can be glamorous, all she has to do is stand still and look stupid'. Far from being stupid, she was fascinated in hearing about problems with radio-controlled missiles and how the control signal could be blocked easily. Mandl became deeply involved with the Nazis and in 1937 Hedy divorced him because of this and moved, first to London, then to Hollywood. Rated by many as the most beautiful woman in the world, she was hired by MGM and given the stage name of Hedy Lamarr.

In Hollywood she became friends with George Antheil who was born in New Jersey, USA in 1900, son of Prussian immigrants. He had studied music in Philadelphia then went to Berlin and later to Paris as a concert pianist. In Paris he became a leading composer and one of his works, *Ballet Méanique*, used sixteen simultaneous pianolas (player pianos). In 1933 he returned to the USA and became a film music composer in Hollywood where he and the exquisite Hedy Lamarr met.

They discussed a wide range of topics, one of which was Hedy's interest in radio control. Thinking about the problem of blocking, she had come up with the idea of 'frequency hopping', but was not sure how this could be accomplished. She had realised that by quickly jumping from one frequency to another at both the transmitter and the receiver, the signal could never be blocked by someone who didn't know the sequence. Antheil had the answer – he had invented a system to co-ordinate the sixteen pianolas in *Ballet Méanique*. The two of them worked on the invention which used slotted paper rolls to synchronise the frequency changes at the transmitter in a high-flying plane and the receiver in a torpedo. It used 88 different frequencies, the number of keys on a piano. With the help of an electri-

### Kirkleagh Somerset Dam Ham Campout

By Harvey Wickes VK4AHW

On the weekend of April 1st and 2nd, the second annual 'Kirkleagh Camp-out' gathering of hams, CBers and their families was held at the beautiful Kirkleagh campsite, on the shores of Somerset Dam in South East Queensland. Jointly sponsored by the Dalby and SCARC Clubs, the event is fast becoming a popular 'don't miss' meeting. This year over 60 people attended, along with quite a few youngsters, who were difficult to count because they were constantly on the run. Hams and their families came from near and far, several even driving down from Rockhampton for the weekend.

The meeting is primarily a social gathering, where local amateurs get to meet face to face the people they have been talking to on air for years. The emphasis is on having an enjoyable time, chatting and comparing notes with like-minded people. Some ham radio activities manage to sneak in of course, with HF, VHF and UHF bands being activated throughout the weekend, in between meals, chats and bush



**The pneumatically-elevated 16 m mast went up easily, but was reluctant to telescope down. A little brute force and intelligence solved the problem.**

walks. There was even a boot sale of pre-loved equipment for the bargain hunters.

This year a hidden transmitter and a few sniffer systems were provided for the kids to use on pedestrian Fox Hunts. This activity proved to be quite popular amongst the younger ones, and even a few Old Timers picked up the sniffer antennas and had a go, some for the first time.

The opportunity arose to run some Foundation License exams, with five candidates sitting. All five passed their practicals tests, and three passed the theory as well, so congratulations to them. There were two candidates who narrowly missed out on their theory, but they are bound to pass well on their second attempt, after a little more study.

The air is so clear out at Somerset Dam that the stars at night appear to be within reach. The dawn chorus of birds was also really impressive, adding a pleasant component to what proved to be a fantastic experience for all who attended. The campout is planned to be repeated next year, over the first weekend in April. An invitation is extended to all local amateurs, CBers and their families to attend.

End



Wynne Philp, Barbara Fowler, and Carole Stuart VK4FUNN at Kirkleagh

example of a modern VLSI circuit is a Pentium 4 processor which contains over twenty million transistors in a chip about 20 mm x 20 mm.

Often, for a few dollars or less, it is possible to get off the shelf an IC to do a job which would have been a major undertaking or impossible just a few years ago. ICs have made our modern industries and lifestyles possible. Radio receivers and transmitters, TVs, digital cameras, laptop computers, MP3 players, car fuel injection systems, GPS receivers – everywhere around us are technological miracles that our parents could not even have dreamed of, all made possible by the ubiquitous integrated circuit. Thanks, Jack Kilby and rest in peace.

End

### Car Radio Installation

A Pelican Droppings report

We have previously reported on member's solutions to the installation of ham radios in their cars. As dashboards vary so there are different solutions. Shown here in the photo below is June Sim's (VK4SJ) solution for her Pajero 4WD. The radios are a 3-band FM transceiver and a Kenwood HF transceiver type TS-2000. For more information talk to June.

End



## Integrated Circuits

A Pelican Droppings Review by Tony Thorrold VK4KKY

With the death in June 2005 of Jack Kilby, the inventor of the integrated circuit, this is a fitting time for us to look at integrated circuits and their development. Until 1947 all active electronic circuits contained vacuum tubes. The invention of the transistor dramatically changed this and by 1958 the first integrated circuit (IC) had been made.

By definition an IC, popularly called a 'chip', is "a complete circuit including active and passive components and their interconnections, manufactured on a single substrate". It is very much smaller than an equivalent circuit made from discrete components. The circuit, comprising transistors, diodes, resistors, capacitors and interconnecting 'wires' is directly built up in a thin slice of material called the substrate. Each component is microscopic in size and this makes it possible to generate circuits and electronic functions that would be quite impossible using discrete components.

Silicon is used as the substrate of most ICs and most high-speed digital and analogue circuits are based on bipolar junction transistors. The highest density ICs such as microprocessors and memory chips use MOSFETs and some ICs use a combination of technologies, for example JFET transistors for low noise and high speed combined with bipolar transistors for high output power. ICs can be divided into several different 'sizes'. Small-scale integration (SSI) refers to circuits containing up to about ten components and these had been developed by 1968. Medium-scale integration (MSI) circuits containing 10 to 100 components soon followed and by 1970 large-scale integration (LSI) circuits containing several thousand components were being made.

In 1971 Intel produced the first microprocessor chip, containing all the arithmetic, logic and control circuits necessary for the processing unit of a computer. Since then the number of components on a single IC has been doubling about every two years or less. Very large-scale integration (VLSI) circuits contain more than several thousand components. Many of us will remember the early (1984) IBM personal computers which operated with a 286 (80286) processor containing about 200,000 transistors. The 386, with 300,000 transistors and the 486 with over 1million transistors, soon followed. An

## Using a PC Serial I/O Controller & Analog Sampler

by Geoff Combes VK4GWC

I built one of these devices from a project in Silicon Chip (Ref. 1) earlier this year. For the experimenter it is a useful aid as an automatic, hands-free recorder and controller when conducting tests on a circuit. In this issue I will describe how I used it's analog sampling function.

But first, what is it? Its purpose is to measure variables and log them in a PC file via a serial interface (the inputs), and control the behaviour of the external device being tested through terminals and relays (the outputs). There are many such commercial devices available; this is a simple one. The diagram in Fig.1 describes its several parts:

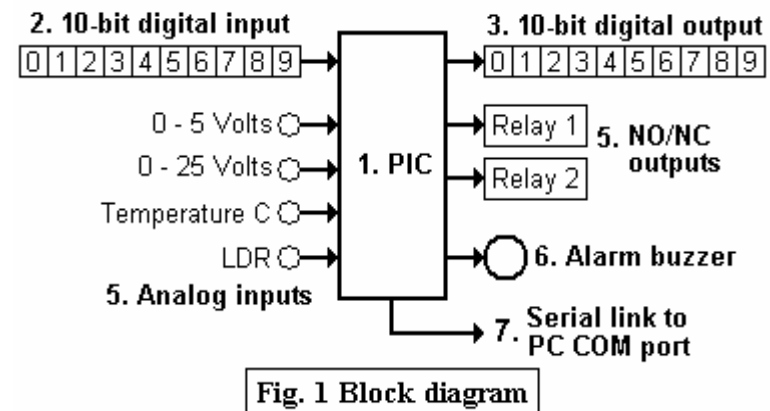

Fig. 1 Block diagram

Item 1 is its heart, a PIC16F877A that carries out all the input and output functions in conjunction with graphical interface software on the PC. The device has no memory cache for data, all data logs are in the PC software program. This means that the device must always be connected to the PC's computer program to function.

Item 2 is a 10-bit digital input (a terminal strip).

Item 3 is the corresponding 10-bit digital output (a terminal strip).

Item 4 are the four analog inputs comprising: 0-5V; 0-25V; Temperature and Light, a light-dependent resistor (LDR). In my case the temperature and light sensors are remotely attached to the device by 600 mm flying leads.

Item 5 are outputs driving two SPDT relays, providing either NO or NC contacts.

Item 6 is an output buzzer, on board the device PCB.

Item 7 is the serial data cable connecting the device to the PC.

The graphical interface software can be programmed to configure the 10-bit digital output, to operate relays 1 & 2 and to sound an alarm



Fig.2

sons to each boat that was propelled by a boatman using a large oar at the stern. The trip through the picturesque canals took an hour and our boatman sang songs with many verses as we were glided along. We saw women doing their washing in the canals, others sitting out in the sunshine preparing the vegetables for the evening meal. We wondered if the vegetables were washed in the canal water. #Our next stop was a Pagoda on Tiger Hill called The Leaning Cloud Rock Pagoda. It was built in the 10th century entirely of brick and began to lean 400 years ago. It now has a lean of two degrees and is seven stories high. To reach it meant climbing 150 steps. As my right knee was still painful after the waterfall trip I stayed in the bus with several others. We were driven to the other side of the hill where we had a clear view of the Pagoda from the parking area. Here we enjoyed a rest. After the Pagoda trip, we headed directly back to Shanghai and the hotel for dinner. Later we drove to the Bund area again to see Shanghai by night with all the buildings lit up. Some of the buildings changing colour as time passed. It was a beautiful sight. End

### BARCFEST 2006

**Saturday 13th May**

**At Mt. Gravatt Bowls Club**

1873 Logan Road, Upper Mt. Gravatt

Opening time 10:00 AM

For more visit <http://www.qsl.net/vk4ba>

Advertisement

**Mark's Plumbing Service**  
Lic: 19095

For Good Reliable Service

- Maintenance • Bathroom Renovations • Roof Repairs
- Domestic Installations • Drain Cleaning • Hot Water Systems

24 Hours - 7 Days Emergency Service

**PHONE: 0401 648 199**



**The Wonderland look of modern Shanghai**

be restored in the 18th century. This house and garden was the residence of a retired bureaucratic official who stated at one time that he “Would have sooner become a fisherman”: hence the name, Master of the Nets.

Some of the furniture in the residence was over 400 years old. The gardens are rather small but the layout and the use of a combination of stones and a pond made the gardens look a lot larger. There were silk painters present; one small silk painting can take up to two days to complete.

#The next stop was at a silk factory where we saw the process from silk worms, cocoons, spinning the silk thread, weaving the silk threads and then to the section where the 2nd class cocoons are opened, stretched, dried and then made into silk-filled quilts. We were given some time to make purchases at the store and then went to lunch at the factory complex. Among some of the things I learnt about silk was that it takes around ten cocoons to make one layer, these are the ones stretched on a frame first to dry then four women pull from each corner to enlarge this one layer. It then takes around 100 layers to make one queen size quilt, so in all about 1000 cocoons are used per quilt: no wonder they are so expensive. After lunch, we drove to one of the canals where we boarded small boats, eight per-

Temperature		°33
Temperature		°33
Temperature	HEATING UP	°34
Temperature		°35
Temperature		°35
Temperature		°36
Temperature		°36
Temperature		°37
Temperature		°37
LDR Resistance	OFF	102417 Ohms
Temperature		°38
Temperature	COOLING DOWN	°37
Temperature		°37
Temperature		°36
LDR Resistance	OFF	102417 Ohms
Temperature		°35
Temperature	COOLING DOWN	°34
Temperature		°33
LDR Resistance	ON	4761 Ohms
Temperature		°33
Temperature		°33
Temperature	HEATING UP	°33
Temperature		°33
Temperature		°34
Temperature		°34

**Fig.3 Temperature data log after adjustment.**

through the buzzer.

That's what it is, now let's see how I used two of the analog inputs in a real test carried out on a home-brew yoghurt maker. The circuit of the yoghurt maker has a temperature sensor and on-off heater controlled by an LM311N comparator. The reference voltage and hysteresis for the comparator were set by design to provide a temperature range within the yoghurt maker insulated container of from 35 to 38 C, about right for making yoghurt.

The purpose of the test was to see if the temperature range set by design was being achieved. Over-runs at the high and low settings were expected, but how much were they? The temperature sensor

was placed inside the container and the LDR was taped to the LED showing whether the heater was on or off. The set-up is shown in Fig.2. The insulated container was empty for the test. The logging interval was set at 1 minute in the software.

The first test run showed a temperature range of 33 to 43 C. This was too wide and 43 C was too high. The hysteresis was halved by changing one resistor in the circuit and the set point for temperature increased slightly. The second test run took 2 1/2 hours and the latter part of the data log is shown in Fig. 3. The words HEATING ON, HEATING OFF, OFF and ON were added to the log. The log can also show date and time. This log shows a temperature range of 33 - 38 C. In practice the glass jar containing the pre-heated yoghurt milk mixture would be held at the average temperature of the range because of its mass; that is at 35 C, ideal for making yoghurt.

The test highlighted a deficiency in the software design; namely that it could only log one input. As this test required logging of two inputs it was necessary to standby while testing to change the input manually, switching from temperature to LDR and back again when required. If both inputs were logged at each logging interval (one minute in this case) then the entire test could have unattended.

In future issues I hope to illustrate other uses for this handy device; in particular the 10-bit digital input/output and its use as a programmable logic controller.

Shortly after building this unit, DSE produced a kit (K-3090) at a price lower than I paid for parts. As mentioned earlier, I made the temperature and light sensors as 600 mm long flying leads that plug in to the PCB (see Fig.2) rather than being mounted directly on the PCB. This can be done using 2-pin headers and plugs without altering the PCB.

Ref. 1 Silicon Chip Nov 2005, page70.

End

### **Coates Queensland Rally Championship 16,17,18 June 2006**

Volunteer radio operators are needed to provide communications at check points.

Please contact any of:

Ray VK4YRS Geoff VK4KEL Richard VK4YRP

## **China Odyssey—Part 4 (Final)**

By June Sim VK4SJ

### **Day 22 Guiyang to Shanghai.**

#We had to be at the airport early for our two-hour flight to Shanghai. We were met at the airport by Amelia ( Qiu), who was to show us all Shanghai in three days. Amelia talked non-stop from the airport to the Hotel and it was the same every time we got on the bus. Eventually we were getting a little too much of Amelia and we hoping she would run out of steam or get laryngitis. Shanghai was quite an eye-opener, with the multi-flyovers, elevated subways and modern skyscrapers. Shanghai has a population of 16 million. We had lunch at one of the old colonial hotels that still survives, and then we were driven a short distance to one of the new modern hotels, The Equatorial Hotel, in which we were booked. I was on the 10th floor with a good view of the elevated road and skyscrapers. After checking in, we were returned to the bus to travel to the Huangpu (Yellow) River for a tour of the Bund; one of the showpieces of the Shanghai waterfront. The modernized river front was packed with tourists, touts, postcards sellers and the \$ 10 to \$ 20 Rolex watch sellers. We were warned to be on the lookout for pickpockets because of the crowds. #Modern buildings dotted the skyline on the other side of the river and there was a constant movement of traffic from large container ships to small launches going up and down the river. Along our side of the river were many of the older colonial buildings, still standing but over-shadowed by modern skyscrapers.

### **Day 23 Shanghai**

We set out early in the morning for Suzhou, a two-hour drive from Shanghai, and known as the Venice of China because of its many beautiful canals. On the way, we passed 20 km of grid-locked highway, all trying to head into Shanghai; we were pleased we were heading out of town. Much of the land between Shanghai and Suzhou is re-claimed swampland, now occupied by huge industrial estates and housing estates for the workers in the factories. Many popular names were seen on the factory buildings: Panasonic, Makita, VW and Bosch were just a few spotted as we sped by. #Our first stop in the city of Suzhou was at a beautiful garden and house and pool complex called The Master of the Nets. This garden was laid out in the 12th century, later to fall into ruin and finally to